

## Split Hubs

Steel

### SPECIFICATION

#### Split Hub

Steel

- Sintered
- Black oxidized with vapor

#### Socket cap screw ISO 4762

Steel, plain

### INFORMATION

Split hubs GN 150 are distinguished by the method of simple clamping to any shaft.

This can be achieved without prior machining of the shaft, eliminating clamping parts and assembly work.

A further advantage is the positioning of the lever arm to any required position.

The shaft tolerance should be within h11; to transmit higher torques the hub can be supplied with a keyway.

### ACCESSORY

- GN 310 Gear Lever Handles (see page 566)

### TECHNICAL INFORMATION

- ISO-Fundamental Tolerances (see page A21)

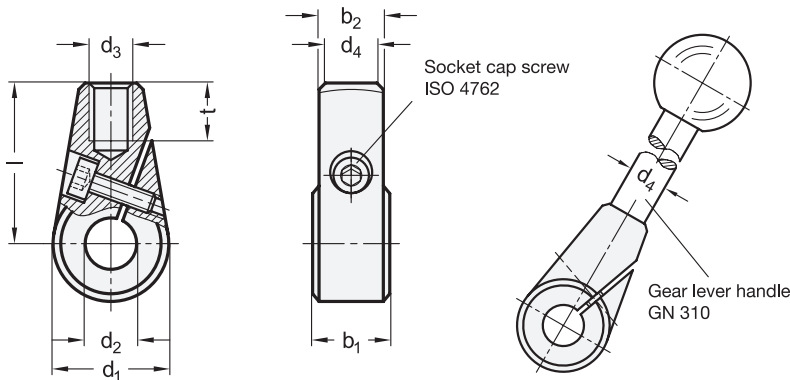

### GN 150

Description	d1	d2 Bore	b1 ±0.2	b2	d3	d4	Length l	t min.	⚖
GN 150-24-B10	24	B 10	15.5	13	M 8	10	36	11	63
GN 150-24-B12	24	B 12	15.5	13	M 8	10	36	11	74
GN 150-28-B12	28	B 12	17.5	15	M 10	12	41	14	113
GN 150-28-B14	28	B 14	17.5	15	M 10	12	41	14	107
GN 150-32-B14	32	B 14	19.5	17	M 12	14	45	16	164
GN 150-32-B16	32	B 16	19.5	17	M 12	14	45	16	160